



the
100_{mm}
filter system

Introduction



THERE IS A REASON WHY LEE FILTERS HAS ESTABLISHED A WORLDWIDE REPUTATION FOR QUALITY THAT IS SECOND TO NONE. IT IS BECAUSE EVERY FILTER THAT LEAVES THE FACTORY HAS BEEN HANDMADE AND INSPECTED BY ONE OF OUR HIGHLY SKILLED STAFF, WHO ENSURE IT MEETS OUR EXACTING STANDARDS.

This rigorous process and attention to detail at every level means that LEE Filters has, since its inception in 1978, been assured of its position as the benchmark in camera filters – its status backed up by the many photographers worldwide who continue to recommend its products for both film and digital photography.

Despite the wide availability of image manipulation programmes, digital photographers are increasingly recognising the benefits of refining the image and ensuring it is correct in-camera. The less work required at the computer, the more time can be spent in the field.

Any system has to start with the fundamentals, and with LEE Filters it is no different.

At the core of any photographer's kit – whether amateur or professional, and whether shooting film or digital – is the filter holder. Deceptively simple and highly versatile, it is all any photographer needs to ensure accurate and creative results.

A long-established history of supplying filters to the film, television and theatre lighting markets, where the demands are stringent and exacting, gives LEE Filters the freedom to apply the same principles to its photographic products. It's quite simple. Inferior filters result in a loss of picture quality.

LEE Filters, however, offers the assurance that its products complement the standards set by camera and lens manufacturers. Compromising picture quality is not an option.

Contents



04 [Getting started](#)

08 [Publications from LEE Filters](#)

09 [The 100mm System](#)

12 [Filter holders](#)

14 [Adaptor rings](#)

16 [Lens hoods](#)

18 [Filters](#)

22 [Neutral density filters](#)

24 [The Big and Little Stopper](#)

28 [Polarising filters](#)

31 [The Landscape Polariser](#)

32 [Resin sets](#)

39 [Single effects filters](#)

43 [Technical filters](#)

44 [Polyester technical sets](#)

46 [Colour control](#)

50 [Black & white photography](#)

52 [Pouches and protection](#)

54 [Accessories](#)

55 [Lighting filters](#)

57 [Index](#)

Getting Started

Digital SLR Starter Kit

If you're new to the LEE Filters system, this is what you'll need to set you on your way. The Digital SLR Starter Kit comes with the filter holder already assembled, so all you need to do is to slot in either the 0.6 neutral density (ND) grad, or the ProGlass 0.6 standard ND filter, clip it to your adaptor ring* and start shooting.

The ProGlass ND filter is designed to cut out more infrared and UV light than the standard resin version. The result? A cleaner, crisper result, with fewer colour aberrations when shooting in challenging light.

A cleaning cloth ensures the filters remain free of dust, and the kit is all packed in a neat triple pouch.

Your Digital SLR Starter Kit includes:

- Filter holder
- ProGlass 0.6 ND standard (100 x 100mm)
- 0.6 ND hard grad (100 x 150mm)
- Cleaning cloth
- Triple pouch

*Adaptor Ring not included, needs to be purchased separately.



Neutral density filters

There are two types of neutral density filter: graduated and standard. Both are typically available in strengths of 0.3, 0.6 and 0.9 – equating to one, two and three stops respectively.

Neutral density filters have no impact on colour balance, and should not be confused with grey filters. They can be used alone or in combination with other types of filter – a warm-up, for example.

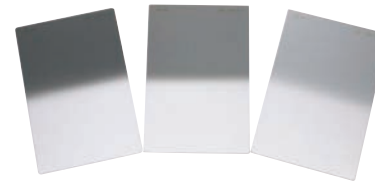

Neutral density graduated filters

The neutral density graduated filter (also known as an ND grad) is used to balance the exposure within a scene – typically when the sky is brighter than the foreground.

ND grads can be used both horizontally and at an angle, and more than one can be stacked on top of the other, for extreme variations in exposure across the composition.

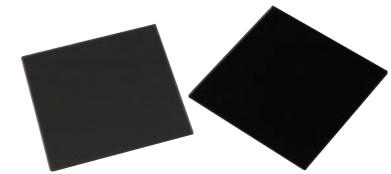

Neutral density standard filters

The only difference between ND grads and ND standards is that the standard is coated evenly across the entire filter, rather than partially.

The ND standard is used in two main ways: to reduce the quantity of light hitting the camera's sensor, or film, permitting longer shutter speeds; and to reduce the sensitivity of a sensor in a DSLR that has a high minimum ISO setting (ISO 200 or above).

When first using ND standards, experiment with slow shutter speeds in order to learn exactly their impact on moving subjects, such as clouds, water or windblown leaves.

Getting Started

Long exposure filters

Photography isn't only about fractions of a second. Long exposures have the ability to render time and movement in a way that produces images full of atmosphere and intrigue. This is where the Big & Little stoppers come in.

Just a single filter allows the user to increase their exposure to many minutes, rendering clouds soft, water smooth and milky, car headlights as streaks of colour or people as abstract, blurred figures.

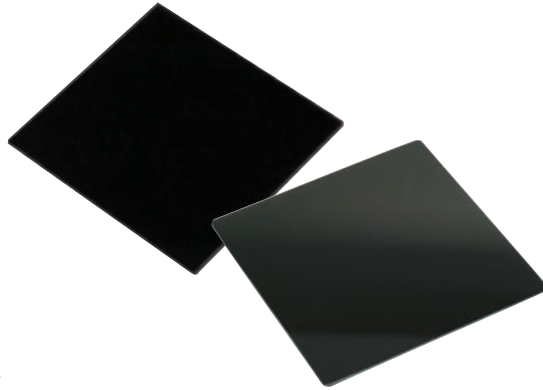

Landscape polariser

When light bounces off a flat, non-metallic surface – such as glass or water – it becomes polarised.

This means that all the reflected lightwaves vibrate in the same plane. The result is glare, which creates extremes of contrast, is difficult to control, and generally confuses the scene. A polarising filter cuts out this glare, removes reflections and results in more saturated colours. The strength of the polarised effect depends on the rotation of the polarising filter.

A super slim, circular polariser for use on all camera types, The LEE landscape polariser is the ultimate polariser for outdoor photography. Covering superwide lenses and with a pleasant slightly warm colour bias.



Foundation kit

The Foundation Kit – the basic filter holder – attaches to the camera's lens via an adaptor ring. The holder is suitable for between one and four filters and is compatible with any camera format, whether film or digital.

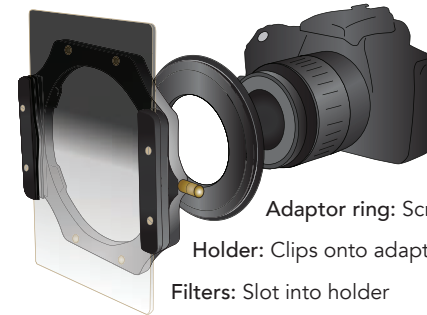

Adaptor ring: Screws onto lens

Holder: Clips onto adaptor ring

Filters: Slot into holder

Universal hood

A versatile accessory, the Universal Hood shades lenses on any camera from DSLR or film SLR to medium format. It comes assembled with two filter slots, but can also be configured to take different filter combinations. It allows the effects of flare to be controlled, leaving the photographer to concentrate on creative composition.



Publications from LEE Filters



Learn the best way to use your filters

Whether you shoot film or digital, Inspiring Professionals and Inspiring Professionals 2 are the only guides to using filters you'll ever need. Produced by LEE Filters, with contributions from professionals at the top of their field, these hardback books feature not only some of the finest landscape and architectural photography, but also numerous hints and tips from the likes of Joe Cornish, Charlie Waite, David Ward, Mark Denton, John Gravett, David Noton, Jeremy Walker, Paul Gallagher and Tom Mackie.



Inspiring Professionals ebooks

Both books are also available as ebooks from the iBooks Store (suitable for Mac and iPad). These multi-touch versions have been specifically designed for the best possible experience on screen. The high quality images can be viewed full screen or alongside the commentary and diagrams that explain which filters were used for each shot.



Xposure

Featuring interviews with some of the world's most respected photographers, advice on everything from neutral-density graduated filters to long-exposure photography, and analysis of what goes into making a successful image, Xposure – the online magazine from LEE Filters – is packed full of photographic inspiration. Download the latest issue at www.leefilters.com.

The 100mm filter system



AT THE CORE OF THE LEE FILTERS SYSTEM IS THE HOLDER, WHICH CAN BE CONSTRUCTED WITH UP TO FOUR SLOTS, AND IS INTENDED TO BE VERSATILE AND STRAIGHTFORWARD TO USE, FREEING UP THE PHOTOGRAPHER TO CONCENTRATE ON TAKING THE PICTURE. THE HOLDER IS DESIGNED TO BE COMPATIBLE WITH 100MM FILTERS – LEE FILTERS' STANDARD WIDTH.

TO FIT THE HOLDER TO THE LENS, AN ADAPTOR RING IS REQUIRED. THERE ARE TWO TYPES OF LEE FILTER ADAPTOR RING: ONE FOR GENERAL USE, AND ONE FOR WIDEANGLE LENSES.

10 [Holder versatility](#)

12 [Filter holders](#)

14 [Adaptor rings](#)

16 [Lens hoods](#)

Holder versatility



To position the graduation line slide the filter up and down in the holder.

The LEE Filters holder has been designed with almost every photographic eventuality and combination in mind. Up to four filters can be used in one holder. A combination of different types of filter, such as neutral density and warm-up if shooting colour, whether film or digital. Or red and neutral density standard (to darken blue skies and slow down the exposure) if shooting with black & white film, for example.

Crucially, once fitted to the adaptor ring, the holder can be rotated to any angle. This permits the photographer to balance the exposure even when the brightest areas fall, say, within the top left hand 'triangle' of the scene.

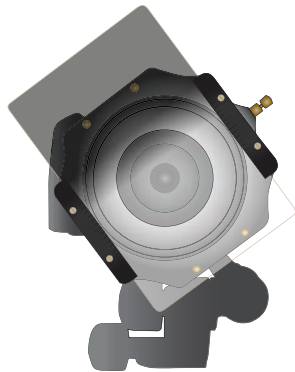

Don't forget that ND grads can also be used 'upside down' – with the filtered section at the bottom and the unfiltered section at the top – on occasions when the lower part of the frame is brighter than the top part.



An ND grad should be positioned at the point where the brightest area of the frame meets the darker area. This is achieved simply by sliding the filter up and down in its holder, assessing the effect through the viewfinder, until the correct point is reached.

When using multiple filters in one holder, it is crucial to take into account the possibility of vignetting. The higher the number of filter guides, the narrower the angle of view becomes and, therefore, the higher the likelihood of vignetting. The approximate limitations are as follows:

Number of filter guides	Minimum focal length
One	16mm
Two	17mm
Three	21-24mm

*All focal lengths are full-frame digital or 35mm SLR equivalents

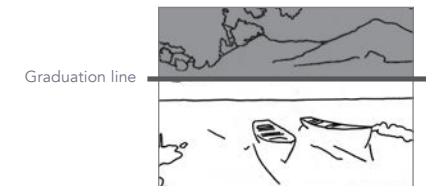

Graduation line

It is possible to fit a 105mm accessory ring to the front of the holder, which allows a polariser to be fitted and rotated independently of any other filters. It is also suitable for use with wideangle lenses.

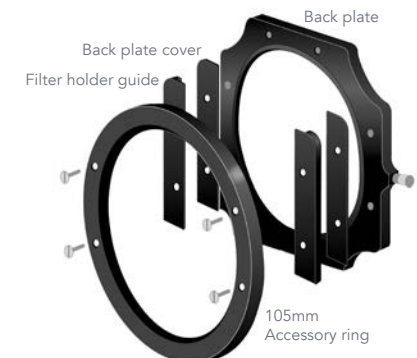

Back plate cover
Filter holder guide

Back plate

105mm
Accessory ring

Holders

Foundation kit

The Foundation Kit is fundamental to the LEE Filters system. It takes standard 100mm filters, and can be constructed to take up to four filters at any one time (remember, though, the more filter guides added, the higher the likelihood of vignetting with wideangle lenses). The Foundation Kit, like all others, clips onto the adaptor ring which, in turn, screws onto your camera's lens.



How the holder is constructed

- Fit the back cover plates to the back plate (see diagram below)
- Fit the filter holder guides (up to four guides, or slots, can be used with one holder) to the back cover plates
- Fit the front cover plates to the filter holder guides

Single filter configuration

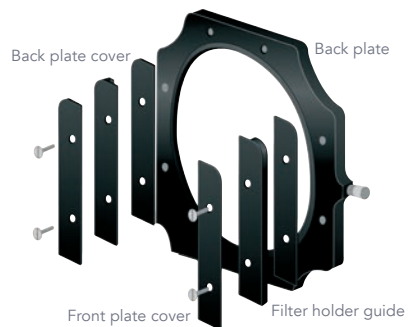

Three filter configuration



Professional kit

The Professional Kit features two filter holders and a tandem adaptor to join them together. This allows independent rotation of grads, as well as the option to use more than four filters if desired.



Push-on filter holder

The push-on filter holder has been specifically designed to fit straight to certain large format wideangle lenses which otherwise will not take a filter system. It takes the standard 100mm filters and fits directly to lenses with an outside diameter of 100mm (filter thread often 95mm). It can be custom adapted to fit lenses or centre filters of smaller diameter, but is not generally the best option for sizes less than 86mm.



Upgrade kit

The Upgrade Kit contains a filter holder and a tandem adaptor and converts your foundation kit into a professional kit.



Starter kit

Like the Digital SLR Starter Kit, a ready assembled filter holder comes as standard with this kit. However, the main difference lies in the inclusion of a Coral 3 graduated filter, which has enough tone to be used both as a grad or an all over warm-up filter. Also included in the kit is a 0.6 ND hard grad, cleaning cloth and triple pouch.

Your Starter Kit includes:

- Filter holder
- 0.6 ND hard grad (100 x 150mm)
- Coral 3 hard grad (100 x 150mm)
- Cleaning cloth
- Triple pouch

*Adaptor Ring not included, needs to be purchased separately.

Adaptor rings

The adaptor ring is crucial to the LEE Filters system. It screws onto the camera's lens and, in turn, the filter holder clips onto the adaptor ring.

The adaptor ring screws onto the lens with a fluid action, thanks to the sturdy construction and aluminium screw thread.

Standard adaptor rings are available in the following thread sizes:

49, 52, 55, 58, 62, 67, 72, 77, 82, 86, 93 and 105mm, as well as Rollei VI and 50, 60 and 70mm bayonet fitting for Hasselblad lenses.

Special sizes can be made to order

Wideangle adaptor rings are available in the following thread sizes:

49, 52, 55, 58, 62, 67, 72, 77, 82mm.

Special sizes can be made to order



Standard adaptor ring

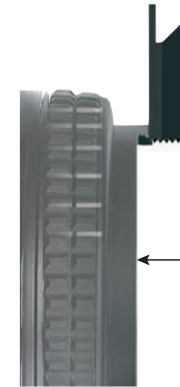

The standard adaptor ring is suitable for use with lenses up to a moderate wideangle. It sits in front of the lens' front thread.

The standard adaptor ring is compatible with lens focal lengths of approximately 24-28mm (35mm SLR equivalent) and upwards.

Adaptor ring for Canon 17mm TS-E f/4L lens

This adaptor ring is compatible with Canon's tilt-shift lens, the 17mm TS-E f/4L. It simply clips on to the front of the lens, and the filter holder attaches to it.

With the adaptor and filter holder in place, more than half of the lens' usual total movement is possible before vignetting occurs.

Wideangle adaptor ring

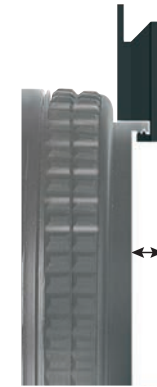

The wideangle adaptor ring is suitable for use with wideangle lenses. It differs from the standard adaptor ring by sitting closer to the front element of the camera's lens. As a result, the likelihood of vignetting is dramatically reduced.

The wideangle adaptor ring is compatible with all lens focal lengths.



Lens hoods



LEE FILTERS LENS HOODS ARE SELF-SUPPORTING – A FEATURE UNIQUE TO THE MANUFACTURER.

This means, quite simply, they have no need for rails or guides in order to be adjusted or maintain their structure. As a result, they are compact and light, so don't become a hindrance to the landscape photographer who prefers to travel light.

The LEE Filters lens hoods can be used alone or in conjunction with filters, allowing the photographer

to shade the lens and enhance their photographic composition at the same time.

Thanks to their flexibility, these hoods can be used at varying angles, so can selectively shade parts of the image, or even match the movements of a large format camera – making them a versatile addition to the photographers' kit bag.

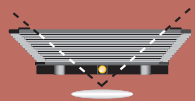

Universal hood closed



Wideangle hood closed

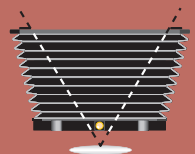

Universal hood open

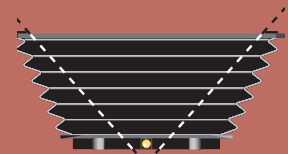

Wideangle hood open

Universal hood

The Universal Hood is designed to suit the needs of most photographers. It works both as a simple lens shade, and in conjunction with filters. It comes assembled with two filter slots, but can also be configured to take different filter combinations. It is ideal for shading wideangle lenses on DSLR, 35mm SLR and medium format cameras.



Wideangle hood

The much larger bellows that are a characteristic of the Wideangle hood, mean it can be used in conjunction with wide or very large lenses – reducing the chances of vignetting.



Filters



LEE FILTERS PRIDES ITSELF ON THE ATTENTION THAT IS PAID TO THE MANUFACTURE OF EACH OF ITS FILTERS. IT IS FOR THIS REASON THAT EACH FILTER IS HANDMADE TO EXTREMELY PRECISE DETAIL, BY THE SKILLED TEAM AT THE FACTORY IN ANDOVER, HAMPSHIRE, ENGLAND.

Each sheet of resin, polyester or glass is carefully inspected and, if any flaws are discovered, it is discarded. Once it has been cut to size, it is delivered to one of the technicians, who proceeds to dip it into the appropriate bath of dye. Neutral density filters are the most complex, requiring a level of precision that cannot be replicated by any piece of factory machinery.

A soft ND grad requires a gentle rocking and dipping action in the dye, so that the transition from the dyed part of the filter to the clear is as smooth as possible.

Hard ND grads, on the other hand, are created with a much sharper dipping action. Careful attention, of course, has to be paid to the point at which the transition occurs.

All filters are then checked in a spectrophotometer for colour density and evenness across the filter.

Only after the filter has undergone a strict process of quality control can it be packaged up for distribution to the company's network of dealers.

It is this attention to detail that ensures LEE Filters products are second to none.

Filter choice

WHETHER YOU CHOOSE FILTERS MADE FROM RESIN, POLYESTER OR GLASS, LEE FILTERS ENSURES THE OPTICAL QUALITY IS SECOND TO NONE.



Resin filters

Resin filters are made from lightweight, optically correct polymeric materials. This ensures they are durable, easy to handle – and can be wiped clean if sprayed by sea or sand during a shoot.

The filters are available as grads – where the top portion of the filter is coloured, and the lower portion is clear – or standard, where the whole filter is evenly coated in the colour or tone.

Resin filters are available either singly or in boxed sets, in sizes of either 100 x 150mm or 100 x 100mm. Sizes to fit other filter holder systems can be custom made. Because all LEE filters are handmade by skilled technicians, their quality is guaranteed.

Glass filters

When necessary, some filters are manufactured in glass, these include Polarisers, the Big and Little Stopper and the ProGlass ND standards. These filters absorb visible and infrared light making them ideal for digital photography.

Polyester filters

Manufactured from the highest quality polyester-based material, the filters are tough and easy to clean.

Polyester filters can be mounted in frames or cut to fit a photographer's existing system. All filter sets are supplied ready mounted for use with the LEE Filters holder system.

An ND standard range is also available in polyester, in strengths from 0.1 to 0.9, while other filters in the technical range include fluorescent correction, ultraviolet absorbing, infrared and colour temperature correction.



Filter choice

Hard graduated resin filters

A hard graduated filter is characterised by a very sharp transition between the coated and uncoated sections of the filter. A hard grad allows the photographer to control with great precision the desired effect on the composition – especially when the transition between two areas in the frame is particularly abrupt, as with a clear horizon, for example. The effect of the filter 'carrying over' from one part of the frame to another would be undesirable.

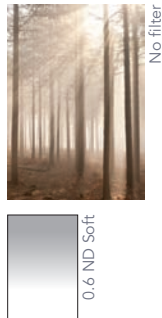
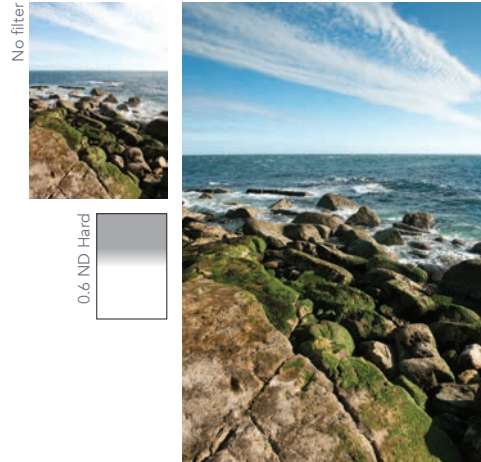

Soft graduated resin filters

The transition between the coated and uncoated portions of a soft graduated filter is less sharp and more subtle than in a hard grad. A soft grad is recommended when the variation in light readings within a scene is less pronounced, and on occasions when the effect of a hard grad would be apparent in the result, showing as a 'line' across the composition. The transition in tones, from bright to dark, should appear very natural when using a soft grad.

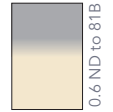

Combination resin filters

These are graduated filters with a different colour at each end of the filter, and although this can be any combination of colours, it will most usually be an ND and a warm-up. The ND balances the exposure of the sky, and the warm-up gives a boost of colour to the foreground.

Popular combinations are:

0.6ND to 81B or 81A	These filters have separate colours top and bottom, and can only be made with hard grad transition.
0.75ND to Coral 2	
0.6ND with 81B	These filters have the warm-up over the entire filter, then an ND overdyed at one end. This gives a warming effect to both the sky and foreground, with the ND balancing the exposure. Available in hard or soft transition, with soft being popular for the darker colours.
0.6ND with 85C	
0.9ND with 81A	

Combination filters are custom made and if used correctly, can yield impressive results.

Neutral density graduated filters



THE PURPOSE OF THE ND GRAD IS TO REDUCE THE BRIGHTNESS OF SELECTED AREAS OF THE FRAME. CRUCIALLY, A TRUE NEUTRAL DENSITY GRAD SHOULD HAVE NO IMPACT ON COLOUR BALANCE, AND THIS IS WHERE LEE FILTERS ND GRADS EXCEL.

Neutral density grads are available in both hard and soft versions, and in strengths of 0.3, 0.45, 0.6, 0.75 and 0.9. The 0.3 strength equals one stop, while each subsequent increment equals an additional half-stop.

Therefore, if, for example, the sky in a scene were two-and-a-half stops brighter than the foreground, a 0.75 ND grad positioned across the sky without encroaching on the foreground would ensure an even exposure.

It is also possible to stack one ND grad on top of one another within the same holder – as long as there are sufficient filter guides to do so – for a variety of effects.

Don't forget, neutral density graduated filters – as with most others in the LEE Filters range – are compatible with both digital and film photography.

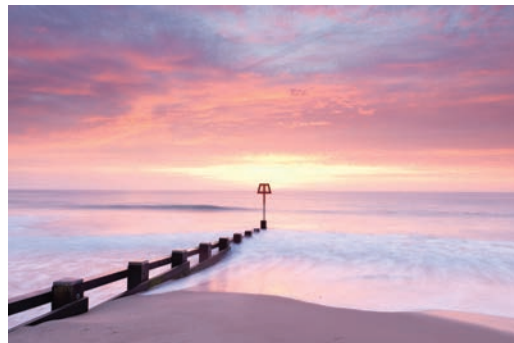

Sometimes it might be necessary to sacrifice a certain amount of shadow detail when using ND grads. It is up to the photographer to visualise whether this loss is acceptable within the parameters of the image.

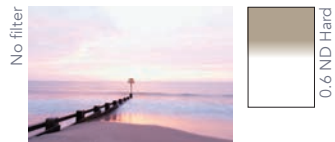

Neutral density standard filters



The aim of the standard ND filter is to reduce exposure equally across the entire frame. It is most commonly used to lengthen shutter speeds in order to blur the movement of, for example, clouds, water, or even people.

An ND filter of 0.9 equates to a reduction of three stops. Therefore, a light reading (without filter attached) of f/8 at 1/2sec would become (with filter attached) f/8 at four seconds.

In a case such as this, the effect of any movement would be quite pronounced.

By stacking, say, a 0.6 ND filter on top, the exposure would be reduced by a further two stops, giving a reading of f/8 at 16 seconds.

When reducing exposures significantly, don't forget to take reciprocity failure into account if shooting film.

ProGlass neutral density standard filters



When shooting digitally, light at the infrared and ultraviolet ends of the spectrum can be problematic. The ProGlass range of filters has been designed with this in mind. These glass neutral density filters are optimised for use with digital cameras, as they absorb more infrared and ultraviolet light than traditional ND filters. The result is a punchier image, with less discolouration in adverse lighting conditions.

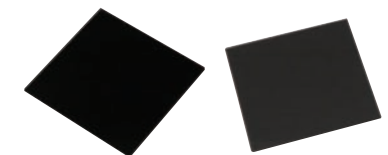

0.9 ND ProGlass (Standard) Filter

0.6 ND ProGlass (Standard) Filter

The Big and Little Stopper

One of the main joys of photography is its spontaneity. Whether shooting from the hip on the street with a discreet rangefinder, using a DSLR and long-lens set-up to capture sports action, or waiting for the light to come right for a large-format landscape composition, it's up to the photographer to make their split-second choice about when to capture their image.

Photography isn't only about fractions of a second. Long exposures have the ability to render time and movement in a way that produces images full of atmosphere and intrigue. This is where the Big & Little stoppers come in.

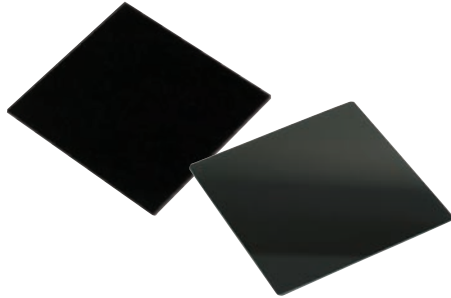

Just a single filter allows the user to increase their exposure to many minutes, rendering clouds soft, water smooth and milky, car headlights as streaks of colour or people as abstract, blurred figures.

For more precise control of your image, both Stoppers can be used in conjunction with other filters – for example, an ND grad or a polarising filter.

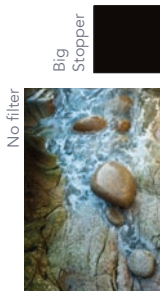

0.75 ND Hard Grad & Big Stopper

What are they?

Each filter allows the user to extend their exposure by six or ten stops, permitting either a longer shutter speed or a wider aperture – or a combination of the two. In the past, such long exposures have been problematic because of the potential for light leaks. Both Stoppers feature a foam gasket which fits firmly against the filter holder, thus ensuring it is light tight.

Manufactured from high-quality glass, each filter fits the standard LEE 100mm Filter Holder, so can be used with a variety of lenses and even in conjunction with other types of filter, such as neutral density grads or warm-up filters.



A Stopper must be placed into the filter slot nearest the lens, with the foam seal facing the holder.

The Big Stopper

With a density of ten stops, the Big Stopper is highly adaptable, proving equally useful not only in lower light conditions but also at times of the day when the light is harsher.



Little Stopper

The Little Stopper

The Little Stopper is ideal for those low-light scenes at the beginning and end of the day, when any exposure compensation greater than six stops might render shutter speeds too long. It's also the filter to choose when you want to retain some texture in moving objects such as cloud or water

The Big and Little Stopper

How to use

- Before fitting a Stopper, first compose your image.
- Take a meter reading without the filter in place, and set your desired aperture and shutter speed.
- Multiply your exposure by the factor of the filter you are using. For the Little Stopper, that is six, for the Big Stopper it is ten. For example, if your meter reading suggests an exposure of 1/250sec at f/11, with the Little Stopper fitted, your exposure becomes 1/4sec, with the Big Stopper it becomes four seconds. If your meter reading suggests an exposure of two seconds, the exposures would become two and 32 minutes respectively.
- With the Stopper filter inserted into the slot nearest the lens, attach the filter holder as usual and make your exposure.
- Always use the sturdiest tripod you can when making long exposures, and take care not to knock the camera or tripod. Cover your viewfinder before releasing the shutter to avoid light encroaching onto the sensor or film and causing flare.



0.9 ND Soft Grad & Big Stopper

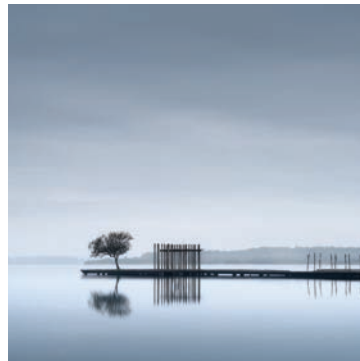

0.6 ND Soft Grad & Little Stopper

Other filters should be set up and positioned in the filter holder as normal before fitting your Stopper filter, remembering to keep the slot in the filter holder nearest the lens free for the Stopper filter.



0.6 ND Hard Grad & Little Stopper

Exposure Guide

The actual density of your Stopper may vary by as much as $\frac{2}{3}$ of a stop. In order to achieve the most accurate exposure for your individual filter, it is recommended that you make some test exposures before first use.

Normal Shutter Speed	with Little Stopper	with Big Stopper
1/2000 sec	1/30 sec	1/2 sec
1/1000 sec	1/15 sec	1 second
1/500 sec	1/8 sec	2 seconds
1/250 sec	1/4 sec	4 seconds
1/125 sec	1/2 sec	8 seconds
1/60 sec	1 second	15 seconds
1/30 sec	2 seconds	30 seconds
1/15 sec	4 seconds	1 minute
1/8 sec	8 seconds	2 minutes
1/4 sec	15 seconds	4 minutes
1/2 sec	30 seconds	8 minutes
1 second	1 minute	16 minutes
2 seconds	2 minutes	32 minutes

If you are using a Stopper in combination with other filters – such as a polariser or warm-up, for example – remember to take their filter factor into account when setting your exposure.

Polarising filters

THE POLARISING FILTER IS AN INVALUABLE TOOL IN THE PHOTOGRAPHER'S ARMOURY. NOT ONLY DOES IT REMOVE POTENTIALLY DISTRACTING REFLECTIONS FROM NON-METALLIC SURFACES SUCH AS GLASS AND WATER, BUT IT ALSO INCREASES COLOUR SATURATION AND DEEPENS BLUE SKIES, MAKING WHITE CLOUDS STAND OUT IN SHARP RELIEF.

Normally, light waves vibrate in all places at right angles to the direction of its travel. Polarised light, however, vibrates in only one plane. A polarising filter, therefore, allows through only those waves which vibrate in the plane parallel to the lines in the filter. By rotating the filter, certain waves pass through it, while others bounce off.

It is this process of cutting out certain waves of light from reflected surfaces that makes colours appear more saturated.

In addition, because much of the light in the sky on a clear, sunny day is polarised, the polarising filter removes these waves, hence the appearance of a deeper, stronger blue in the final image.

The effect of a polarising filter on a scene can be assessed in two ways. If using an SLR, simply attach the filter to the front of the lens, look through the viewfinder, and rotate the polariser until the desired effect is achieved. Alternatively, if using a rangefinder, where its strength cannot be assessed by looking through the lens, hold the filter up to the scene, rotate it until the desired effect is achieved, then place it on the camera's lens.



Circular polariser



No filter

Linear and circular

There are two types of polarising filter: linear and circular. These terms do not refer to the shape of the filter, but rather the way in which the filter modifies the light waves that pass through it. The type of filter required depends on the camera.

If you use an autofocus SLR (digital or 35mm) in, for example, spotmetering mode, you will need a circular polariser. This is because a linear polariser will interfere with the complex metering and AF systems of modern cameras.

If you use a manual focus camera, whether 35mm or medium format, you can use either a circular or a linear polariser.

If you are still unsure of the type of polariser you require, check your camera's instruction manual.

A polarising filter will increase your exposure by $1\frac{1}{2}$ stops.

If using a polarising filter in conjunction with polyester filters, the polariser must be placed in front of the polyester filters, not behind, otherwise it will not function correctly. This problem does not arise when the polarising filter is used in conjunction with resin filters.

Polarising filters



Circular polariser



No filter

Sometimes a fully polarised sky can appear overdone. Experiment with halting the rotation at around 45 degrees to the sun, rather than the full 90 degrees, for a more natural-looking result.

The 105mm rotating polariser

This polariser is attached to the filter system by a special ring, which fits to the front of the filter holder. This allows the polariser to be rotated independently of any other filters in the holder. It is the ideal solution for landscape photography, where a combination of graduated filters and polariser may be required.

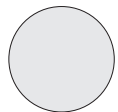

105mm rotating polariser
– circular and linear



100x100mm square polariser
– circular and linear

Polarising filters can be used with both digital and film cameras.

The landscape polariser



Taken at 16mm on full frame sensor with the Landscape Polariser



No filter

The ultimate polariser for landscape photography

Wideangle lenses form a crucial part of the landscape photographer's arsenal, but using polarisers with them can cause problems, because their design leads to vignetting in the corners of the frame. LEE Filters has overcome this problem with the slimline Landscape Polariser, which can be used to a focal length of 16 -17mm on a full-frame DSLR.

The Landscape Polariser is compatible with the two-slot design of the LEE Filter holder, it screws onto the front of the



holder via a 105mm accessory ring (sold separately) and can be used in conjunction with any other slot-in filter in the 100mm system. Being a circular type polariser, it can be used on all types of camera.

The Landscape Polariser also comes with an added advantage for the outdoor photographer: it has a slightly warm bias, which makes it the ideal companion for landscape photography, enhancing gold, brown and orange tones, that are so often associated with the landscape.

Resin sets



THE LEE FILTERS EFFECTS SETS ARE THE BEST – AND MOST ECONOMICAL – WAY OF INTRODUCING FILTERS INTO YOUR PHOTOGRAPHY. FROM THE CLASSICS, SUCH AS THE ND GRAD SET AND SUNRISE SET, TO THE UNUSUAL, SUCH AS THE SELECTIVE STAR AND NET SET – EVERY CREATIVE EVENTUALITY HAS BEEN CATERED FOR.

Each set is presented in a filter wrap. Designed to hold three filters, the wrap can be folded and slipped into a camera bag or pocket. It takes up minimal space, while making the filters easy to select when needed quickly.

Effects Filters aren't restricted to use on their own, either. Any different effect can be combined; the limitations are only the number of filter guides in the holder – and the photographer's imagination!

- 33** [Neutral density set](#)
- 34** [Sky set, Autumn tint set](#)
- 35** [Sunrise set, Landscape set](#)
- 36** [Sky blue set, Coral set](#)
- 37** [Sunset set, Twilight set, Colour grad set, Pale tint set](#)
- 38** [Pop set, Mist set, Selective star set, Net set](#)

All resin sets are 100 x 150mm graduated filters. Please note that standard resin filters are currently not available in sets.

Neutral density grad set

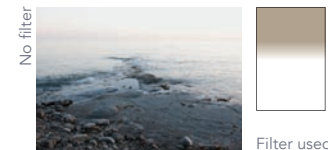
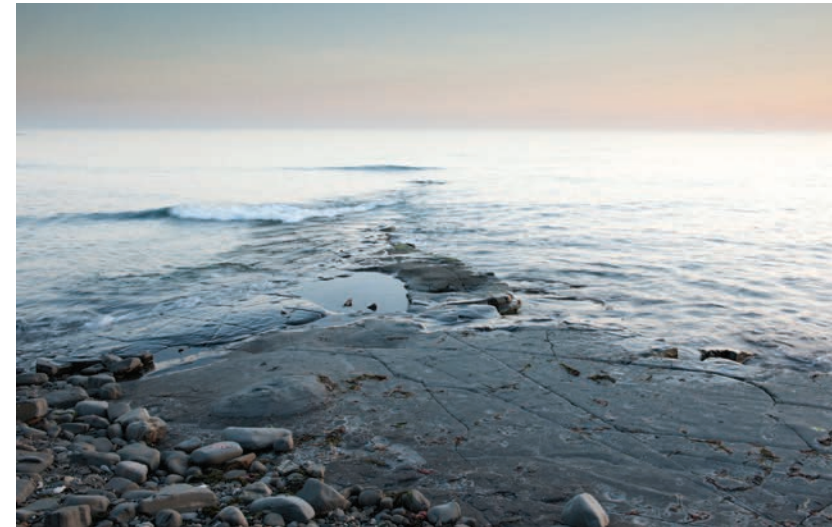
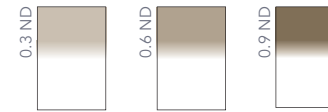

The Neutral Density Grad Set is suitable for use with both digital and film cameras, and features three neutral density graduated filters of 0.3, 0.6 and 0.9 strengths (equating to a reduction of one, two and three stops respectively).

The beauty of the ND grad is that it allows the photographer to reduce exposure in one part of the scene, while leaving the rest unaffected. And because LEE Filters ND grads are truly neutral, there will be no nasty colour casts on the end result.

Neutral density grads are most commonly used when the sky is brighter than the foreground. By placing an ND grad across the bright area, detail is retained and a more balance composition is the result.

If the sky is one stop brighter than the foreground, a 0.3 ND grad would be used; two stops, and a 0.6 ND grad would be used – and so on. Grads can be stacked one on top of the other, or combined with different effects grads, for even more creative photographs.

Sky set

The purpose of the Sky Set is to enhance the colours in the sky, and is particularly useful when a sunrise or sunset hasn't quite lived up to expectations. The Sunset 2 enhances warm tones, typical of the light at the end of the day, the Sky Blue 3 introduces colour into lifeless skies, while the Coral Stripe boosts a selective area of the frame – usually directly above the horizon.

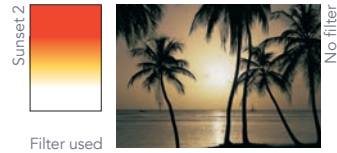
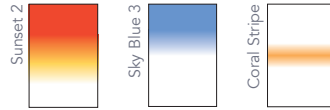

Autumn tint set

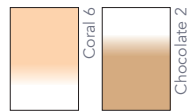

Filters used

The Autumn Tint Set, as the name suggests, is particularly suitable for enhancing the colours in autumnal scenes, making the most of the rich golds, reds and browns that typify the season.

A unique feature of these filters is that they can be used as both hard grads and standards. Because the graduation line is placed 90mm from the top of the filter, the coated portion of the filter is sufficient to cover the whole scene. Alternatively, by raising the filter higher in its holder, it then becomes a grad.

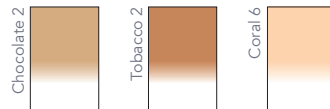

Sunrise set



The light at dawn tends to be rather paler and more subtle than at sunset, and this set reflects this. The strong yellow of the Straw 2 acts as a warm-up, while the Mahogany 1 is suitable for creating a paler effect. The Straw Stripe introduces warmth into the horizon.

Landscape set

This set is designed to complement the landscape – be it urban or rural. The Real Blue 2 brings intensity to faded skies, while an inverted Straw 3 warms the foreground. Suitable for more classic landscapes, the Sepia 2 enhances the colour of rocks, foliage and fallen leaves.

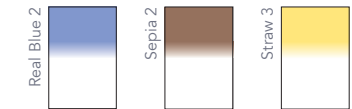

Filters used

Sky blue set

Lifeless skies in both land and seascapes can be enhanced with the subtle use of this set, with each filter increasing slightly in intensity.



Coral set

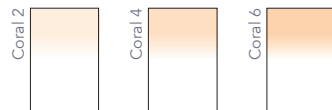

The Coral set – which ranges in strength from pale to mid tone – has a variety of uses. When placed across the sky, a warm, soft orange hue is introduced; when inverted it brings tone to greenery in the foreground. The higher the number in the Coral grad series, the further the colour temperature is corrected.



Sunset set

This popular set adds warmth and definition to both sky and landscape, enhancing the natural colours created by sunsets. The extra-deep coating of the Sunset Yellow filter allows it to be used both as a standard and a grad.



Twilight set

Not to be confused with the Coral Stripe, this pale version permits a subtler approach to the enhancement of the horizon. When used in conjunction with the Mahogany 3, which gives the impression of a 'red sky at night', the effects can be striking. The Twilight filter replicates the deep blue that arises when day crosses into night.

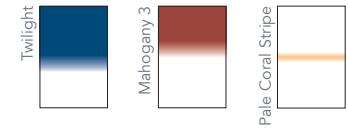

Colour grad set

This set is particularly effective at introducing special effects, by colouring just one section of the frame. By combining two or more filters in the same holder, the colours of red, blue and green can be created. And their versatility doesn't stop there. One filter can be placed to cover the top of the frame, while another can cover the lower part. For example, using the Cyan filter to enhance the sky, and the Yellow filter to warm the foreground.

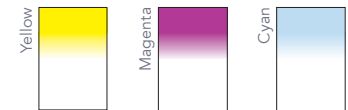

Pale tint set

The number one denotes that each of these filters is the palest of its range. The colours in this set allow the photographer to introduce the subtlest hints of tone to selected parts of the image.

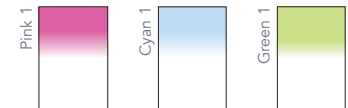

Pop set



The primary colours of red, green and blue form the basis of this set. Like a more intense version of the Colour Grad Set, it can be used creatively to introduce colour into selected areas of the frame. Like other grads, their position can be altered both by rotating the holder, and sliding up and down within the filter guides.

Mist set



The filters in this set are designed to imitate the effects of fog and mist, and are suitable for use either alone or in combination with one another – depending on the desired density. The Stripe, when used in the foreground, gives a sense of the depth of fog, while the Clear Spot takes the viewer's eye straight to the most important part of the frame – wherever the photographer decides that may be.

Selective star set

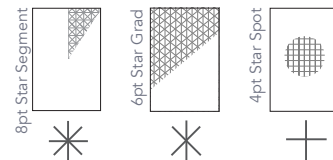

With careful positioning of these filters, a star pattern is introduced into the highlight areas of the photograph. The Star Spot features a circular cluster of markings, while the Star Segment creates stars in a chosen segment of the frame. Finally, the Star Grad features highlights in one portion of the filter, which gradually fade to clear.

Selective net set

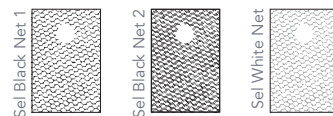

Based on the type of net filter which is commonly used in cinematography, this set creates a subtle soft focus effect. Additionally, the black net filters increase contrast, while the white net filters decrease it. The filters can be moved up and down within the holder to control where the clear spot appears in the photograph. When using the Black Net 1, exposure should be increased by half a stop. When using the Black Net 2, exposure should be increased by one stop.

Single effects filters

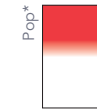

Red

For colour effects.

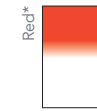

Sunset Red

The red portion of the Sunset Grad.

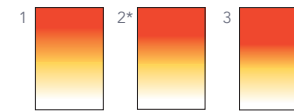

Sunsets

For a sunset effect when shooting into a low sun.



Yellow

For colour effects.



Sunset Yellow

The yellow portion of the sunset grad.

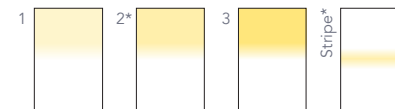

Straw

For a strong warm-up effect when shooting landscapes; accentuates foregrounds when inverted.



Sunset Orange

The orange portion of the Sunset Grad.



Pale Coral

Paler and narrower than the Coral Stripe for a more subtle effect.

*filter available both individually and as part of a set.

Single effects filters

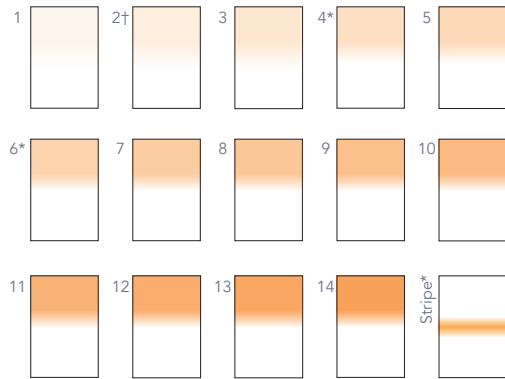

Coral

Slightly pink warm-up filter, more red than 81 series.

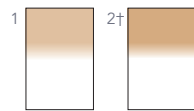

Chocolate

Accentuates brown tones, such as autumn leaves and stone.

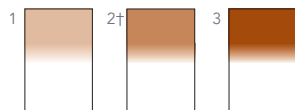

Tobacco

Darker and more red than Chocolate and Sepia filters, with a very strong effect.

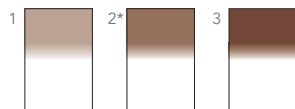

Sepia

For a brown-tinted monochrome appearance, which is less red than Chocolate.

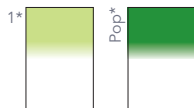

Green

For colour effects.

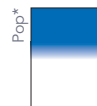

Blue

A deep red-blue, mainly for colour effects.

*available as part of a set. † filter in the set is an extended graduated version.

Single effects filters

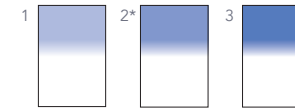

Real Blue

Darker and more black than Sky Blue, for a stronger impact on skies.

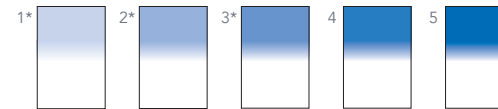

Sky Blue

A green-blue to bring realistic colour into flat skies.

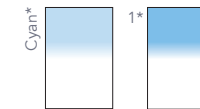

Cyan

For colour effects.



Twilight

Deep blue-black gives a monochromatic twilight appearance.

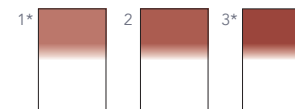

Mahogany

Enhances impression of dawn and evening light in skies; 'red sky at night' effect.



Magenta

For colour effects.



Pink

For colour effects.

*available as part of a set. † filter in the set is an extended graduated version.

Single effects filters

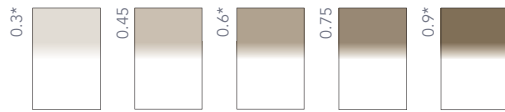

Neutral Density

Reduces exposure in selected areas without affecting colour balance.

When using neutral density grads in conjunction with a DSLR, consider attaching one of a stop less than that suggested by the light reading (e.g. 0.6 instead of 0.9). This is so maximum detail is recorded in the scene, which can later be adjusted in postproduction.



Fog

For an opaque, misty effect, which is different from soft focus.



Low Contrast

A slight white opacity, to lighten darker areas and so reduce contrast.

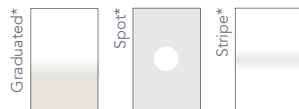

Mist

Introduces a misty effect to selected areas of the frame.

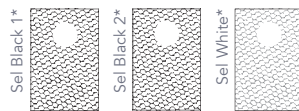

Selective Net

A subtle, soft-focus effect, with hole for a clear centre, if required.

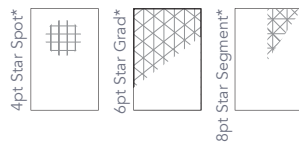

Star

Precision manufacturing process achieves a clear yet subtle star effect.



*filter available both individually and as part of a set.

Technical filters



MOST FILTERS IN THIS RANGE ARE MANUFACTURED FROM THE HIGHEST QUALITY POLYESTER BASE, WHICH IS TOUGH AND DURABLE, AS WELL AS BEING IMPERVIOUS TO WATER AND EASY TO CLEAN.

Because of the high quality of the material used, the optical quality of LEE Filters polyester range is equal to that of its resin and glass filters.

The filters in this range are designed to tackle specific problems, such as correcting colour temperature – whether major or minor – or absorbing light that would otherwise create unwanted casts.

The Black & White Set allows the photographer to adjust certain tones within the frame, while the Soft Set introduces increasing levels of diffusion.

- 44 Colour temperature set, Fine colour temperature set, Warm-up set, Daylight fluorescent set
- 45 Tungsten fluorescent set, Neutral density set, Black & white set, Magenta set
- 46 Soft set, Colour temperature adjustment filters
- 47 Neutral density filters, Combination filters
- 48 Fluorescent correction filters, Arc correction filters, Ultraviolet absorbing filters
- 49 Tricolour filters, Infrared
- 50 Black & white photography

Polyester technical sets

Colour temperature set

This four-filter set is designed to balance the effect of any major colour temperature disparities between light source and film or sensor. This avoids the appearance of colour casts on the final image.

Filter	Conversion	Approx Exposure Increase	Mired Shift
85B	5500K to 3200K	¾ stop	+131
85C	5500K to 3800K	¾ stop	+81
80C	3800K to 5500K	1 stop	-81
80A	3200K to 5500K	2 stops	-131

Fine colour temperature set

Similar to the Colour Temperature Set, above, this set is designed to tackle less extreme colour shifts. It can also be used to introduce subtle warming or cooling effects to the final image.

Filter	Conversion	Approx Exposure Increase	Mired Shift
81D	3700K to 3200K	¾ stop	+42
81A	3400K to 3200K	½ stop	+18
82A	3000K to 3200K	½ stop	-21
82C	2800K to 3200K	¾ stop	-45

Warm up set

Four filters of increasing intensity, primarily used for introducing warmth into both landscapes and portraits.

Filter	Conversion	Approx Exposure Increase	Mired Shift
81	3300K to 3200K	½ stop	+9
81B	3500K to 3200K	½ stop	+27
81D	3700K to 3200K	¾ stop	+42
85C	5500K to 3800K	¾ stop	+81

Daylight fluorescent set

This set of filters ensures – when shooting daylight-balanced film under fluorescent light – that the result is neutral. In addition, there is a range of lighting filters that balances flashlight, too. These are essential because all light entering the camera must be of the same spectral output as the fluorescent source, if the result is to be corrected accurately.

Filter	Function	Approx Exposure Increase	Flash
FL3600-D	Balances warm-white tubes	1 ¾ stops	½ CTO + Plus Green
FL4300-D	Balances white tubes	1 stop	¼ CTO + Plus Green
FL5700-D	Balances daylight/cool white tubes	¾ stop	Plus Green

Tungsten fluorescent set

A three-filter set to allow for shooting under fluorescent lighting when shooting tungsten-balanced film. As with the Daylight Fluorescent Set, there is a range of lighting filters to place over a flashgun.

Filter	Function	Approx Exposure Increase	Flash
FL3600-B	Balances warm-white tubes	¾ stop	½ CTO + Plus Green
FL4300-B	Balances white tubes	1 stop	¼ CTO + Plus Green
FL5700-B	Balances daylight/cool white tubes	1 ½ stops	Plus Green

Neutral density set

The three filters in this set are designed to increase exposure without affecting the colour balance of the picture. They are compatible with all standard film types, and digital sensors.

Filter	Colour	Approx Exposure Increase
0.3 ND	neutral density	1 stop
0.6 ND	neutral density	2 stops
0.9 ND	neutral density	3 stops

Black & white set

Four filters, each of which has a different effect on the tones in a black & white image by absorbing different quantities of colour in the blue and blue-green parts of the spectrum. These filters also can be used for special effects.

Filter	Colour	Approx Exposure Increase
8	Yellow	½ stop
11	Yellow Green	1 ½ stops
21	Orange	1 stop
23a	Light Red	2 stops

Magenta set

Five CC Magenta filters, which are designed to absorb the green cast created by fluorescent lighting. They can be stacked one on top of another for greater absorption, and used in conjunction with colour temperature filters for complete accuracy in colour balance.

Filter	Colour	Approx Exposure Increase
CC05M	Magenta	½ stop
CC10M	Magenta	½ stop
CC20M	Magenta	¾ stop
CC25M	Magenta	¾ stop
CC30M	Magenta	¾ stop

Polyester technical sets

Soft set

Five filters, each of which gradually increases in soft-focus effect. This set is particularly suitable for landscape and portrait photography, when a diffused, romantic result is desired. The soft effect is virtually unaffected by variations in aperture and focal length.

Filter	Type	Approx Exposure Increase
Lee Soft 1	Light soft focus	not required
Lee Soft 2	Soft focus	" "
Lee Soft 3	Soft focus	" "
Lee Soft 4	Soft focus	" "
Lee Soft 5	Strong soft focus	" "

Colour control

Colour temperature adjustment filters

These filters have a variety of uses. Although designed to convert the colour characteristics of a light source to balance with the film type in use, they can also be used deliberately to create a warm or cool overall colour cast.

Description	Filter	Approx Exposure Increase	Conversion	Mired Shift	Resin Grad	Resin Standard	Polyester Standard
Blue for major adjustment	80A	2	3200K to 5500K	-131	✓	✓	✓
	80B	1 ½	3400K to 5500K	-112	✓	✓	✓
	80C	1	3800K to 5500K	-81	✓	✓	✓
	80D	¾	4200K to 5500K	-56	✓	✓	✓
Pale Blue for fine adjustment	82C	¾	2800K to 3200K	-45	✓	✓	✓
	82B	¾	2900K to 3200K	-32	✓	✓	✓
	82A	½	3000K to 3200K	-21	✓	✓	✓
Pale Amber for fine adjustment	82	½	3100K to 3200K	-10	✓	✓	✓
	81	½	3300K to 3200K	+9	✓	✓	✓
	81A	½	3400K to 3200K	+18	✓	✓	✓
	81B	½	3500K to 3200K	+27	✓	✓	✓
	81C	½	3600K to 3200K	+35	✓	✓	✓
Amber for major adjustment	81D	¾	3700K to 3200K	+42	✓	✓	✓
	81EF	¾	3850K to 3200K	+53	✓	✓	✓
	85C	¾	5500K to 3800K	+81	✓	✓	✓
Amber for major adjustment	85	¾	5500K to 3400K	+112	✓	✓	✓
	85B	¾	5500K to 3200K	+131	✓	✓	✓

(mired shift can be negative as well as positive)

Neutral density filters

Neutral density filters reduce light transmission uniformly across the visible region of the spectrum, in incremental steps. Although used mainly in colour photography for reducing light levels without altering the colour of the image, they can also be used in black & white photography. ND filters are particularly useful for compensating for too much light, in circumstances where altering shutter speed, aperture or film speed is not possible or desirable.

Additionally, ND filters can be used creatively to extend shutter speed times when shooting, for example, running water or waterfalls – without adjusting the aperture. Alternatively, the use of an ND filter allows the photographer to increase their aperture by the stop value of the filter used. For example, if a reading suggests an aperture of f/8, but the desired aperture is f/4, the addition of a 0.6 ND filter permits the photographer to open up to f/4.

Neutral Density	Stop Value	Transmission %	Resin Grad	Resin Standard	Polyester Standard	Glass Standard
0.1	½	79.4			✓	
0.2	¾	63.1			✓	
0.3	1	50.0	✓	✓	✓	
0.4	1 ½	39.8			✓	
0.45	1 ½	37.5	✓	✓		
0.5	1 ¾	31.6			✓	
0.6	2	25.0	✓	✓	✓	✓
0.7	2 ½	19.6			✓	
0.75	2 ½	18.75	✓	✓		
0.8	2 ¾	15.9			✓	
0.9	3	12.5	✓	✓	✓	✓

Combination filters

This range of filters which combines the characteristics of ND filters with selected colour temperature adjustments.

CT / ND Combination	Approx Exposure Increase	Conversion	Mired Shift	Resin Standard	Polyester Standard
85BN3, 85BN6, 85BN9	1 ¾, 2 ¾, 3 ¾	5500K to 3200K	+131	✓	✓
85N3, 85N6, 85N9	1 ¾, 2 ¾, 3 ¾	5500K to 3400K	+112	✓	✓
81EFN3, 81EFN6, 81EFN9	1 ¾, 2 ¾, 3 ¾	3850K to 3200K	+53	✓	✓

Colour control

Fluorescent correction filters

This system combines colour temperature conversions and green absorption into one filter, making it suitable for use in various fluorescent-lit conditions. The selection of filter depends on the film in use and the type of fluorescent light.

Film Type	Filter	Approx Exposure	Light Source Increase	Resin Standard	Polyester Standard
Tungsten (3200K)	FL 5700-B	1 ½ stops	Cool White 5700K	✓	✓
	FL 4300-B	1 stop	White 4300K	✓	✓
	FL 3600-B	¾ stop	Warm White 3600K	✓	✓
Daylight (5500K)	FL 5700-D	¾ stop	Cool White 5700K	✓	✓
	FL 4300-D	1 stop	White 4300K	✓	✓
	FL 3600-D	1 ¾ stops	Warm White 3600K	✓	✓

Arc correction filters

These filters are designed to correct colour balance under mercury vapour or high pressure sodium lighting. There are versions for both daylight and tungsten-balanced film.

Film Type	Filter	Approx Exposure Increase	Light Source	Resin Standard	Polyester Standard
Tungsten (3200K)	HPS-B	2 stops	High Pressure Sodium	✓	✓
	MV-B	2 stops	Mercury Vapour	✓	✓
Daylight (5500K)	HPS-D	3 stops	High Pressure Sodium	✓	✓
	MV-D	2 ½ stops	Mercury Vapour	✓	✓

Ultraviolet absorbing filters

This range of filters absorbs varying degrees of ultraviolet radiation, which is the cause of haze and bluish casts in distant landscapes, water scenes and aerial photography.

Filter	Description	Resin Standard	Polyester Standard
1A	Maximum absorption of 0.076A (84%) at 535 nanometres	3	3
1B	Maximum absorption of 0.086A (82%) at 525 nanometres	3	3
2B	UV Absorption greater than 0.72A (19%) at 400 nanometres	3	3
2C	UV Absorption greater than 0.39A (40.5%) at 400 nanometres	3	3

Tricolour filters

colour	Filter	description	approx exposure increase	Resin Standard	Polyester Standard
Tricolour Red	25	Separation filter. Maximum transmission above 610 nanometres. Also used for black & white contrast effects, haze penetration in aerial photography, and removing blue in infrared photography	2 ½ to 3 stops	✓	✓
Tricolour Blue	47B	Separation filter. Maximum transmission at 440 nanometres	2 ½ to 3 stops		✓
Tricolour Green	58	Separation filter. Maximum transmission at 530 nanometres	2 ½ to 3 stops		✓

Infrared

colour	Filter	description	Resin Standard	Polyester Standard
Infra-Red	87	This visually opaque filter is used in infrared photography to absorb unwanted visible light. Transmission begins above 730 nanometres.		✓

Black and white photography

Filters for black & white photography

Filters are widely used by black & white photographers for creative effect – most commonly to increase contrast between sky and cloud. However, care should be taken, because as much as a black & white filter darkens one colour, it lightens another – specifically, any colour that is similar to its own. A red filter, for example, makes a red pillar box appear almost white, and a blue sky as almost black. However, a red filter also absorbs green, which would block up the foreground of a verdant landscape.

Don't always reach automatically for the red filter to enhance a sky. The results obtained from its orange or yellow counterparts can be just as pleasing in their subtlety and, if desired, the sky can be burned in later – either in the darkroom or in postproduction.

The black & white filters in the LEE Filters range can be used in conjunction with others, such as the polariser and neutral density standards and grads.

Colour	Filter	Description	Approx Exposure Increase	Resin Grad	Resin Standard	Polyester Standard
Light Yellow	3	Partially corrects for excess blue in aerial photography.	none	✓	✓	✓
Yellow	8	Darkens sky, cloud and foliage to reproduce correct tones.	+½	✓	✓	✓
Yellow - Green	11	Used to alter the response of panchromatic emulsions, to be equivalent to the natural response of the eye to objects under tungsten illumination. Greens are reproduced slightly lighter in daylight.	+1 ½	✓	✓	✓
Deep Yellow	12	Minus blue filter. Can be used to cancel blue light when infrared-sensitive films are exposed. Also penetration of haze during aerial photography.	+½	✓	✓	✓
Deep Yellow	15	Increases contrast between cloud and sky greater than No.8, for over-correction effect. Also used for copying documents on yellowed paper.	+¾	✓	✓	✓
Yellow Orange	16	Gives even greater over-correction than No.15 Absorbs a small amount of green.	+¾	✓	✓	✓
Orange	21	Contrast filter. Absorbs blue and blue/green.	+1	✓	✓	✓
Light Red	23A	Greater contrast effect than No.21.	+2	✓	✓	✓

This sequence demonstrates how different colours are affected by different filters.

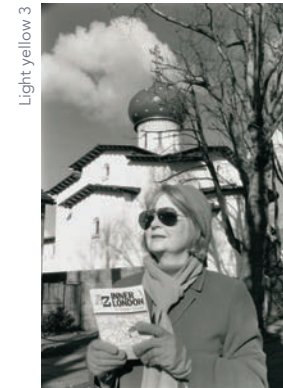

Lightens reds/darkens some blue and blue/green



Dramatically lightens reds and darkens blue and green



Lightens reds/darkens some blue and blue/green



Dramatically lightens reds and darkens blue and green

Pouches and protection

Field pouch

Keeping your filters dry and clean is as much of a priority for your grads, Stoppers and polariser as it is for your lenses. Dust and smears on filters can degrade the quality of your image, and create extra work at the postproduction stage.



The Field Pouch holds 10 filters and can be worn with either a shoulder strap or belt loop. An additional tripod strap allows the pouch to be attached to a tripod for easy access during use.

In order to keep your filters clean, safe and – above all – close to hand so they're there exactly when you need them, LEE Filters has introduced the Field Pouch. A versatile accessory, it will soon become as essential as the filters you carry in it. Its concertina design permits one slot per filter – up to a maximum of ten – and makes each filter easily accessible.

The Field Pouch has three strap options: it can be worn over the shoulder, on a belt loop, or it can be attached to a tripod. As a result, your filters are easy to reach, whether you're on the move or plan to be in one spot for an extended period of time.

Available in black or sand, the Field Pouch is constructed of a tough, durable fabric that will withstand the kind of wear and tear that the average outdoor photographer is likely to subject it to.



Multi-filter pouch

For simple storage of filters, not to mention quick and easy access when on a shoot, the Multi-filter Pouch holds up to 10 filters.

Triple pouch

The Triple Pouch is manufactured from the same tough fabric as standard single pouches, but holds three filters instead of just one – allowing photographers to pack their preferred resin set when heading out on location. The pockets are also wide enough to carry holders and adaptor rings. The pouch features belt loops on the back.



Filter wrap

The Filter Wrap is a simple, yet ingenious design. Made from a microfibre cleaning cloth, it holds up to three filters and can be folded and stored, using only minimal space.

Stopper case

Protect your Stopper filters from unwanted knocks whilst in your camera bag with this protective tin case. The case has a foam insert that holds the filter firmly in place reducing the risk of damaging the filter.



Accessories

System accessories

The range of products compatible with the LEE Filters system includes:

- **Tandem adaptors**
- **Mounts**
To permit the use of 84mm filters – both square and rectangular – within the LEE Filters system.
- **Mounts**
For polyester filters – both 75x75mm and 100x100mm.
- **Holder guides**
Guides for using extra filters.
- **Screws**
Of varying lengths.
- **Filter cleaning solution**
For use on resin and glass filters.



- **Cleaning cloth**
A high quality cleaning cloth which can be used either dry or with the cleaning solution.
- **Lens cap**
The lens cap allows you to leave the adaptor ring attached at all times while keeping the front element clean and safe. They are made of white polypropylene and, when attached, can be used to white balance a digital SLR, or as a makeshift incident lightmeter on any camera. They can also be written on to identify lenses in the camera bag.
- **Rangefinder face blades**
These calibrated metal face blades simply replace the existing front blades on the Standard LEE Filter holder, enabling quick and consistent positioning for graduated filters when used on rangefinder cameras.



Lighting filters



Pro-pack

The LEE Filters Pro-Pack kit contains 23 specially selected different sheets of filter material, and represents a versatile package for the studio.

15 colour effect-filters used for lighting backgrounds and creating special effects. Colours are yellow, straw, deep amber, orange, primary red, dark pink, magenta, peacock blue, dark blue, fern green, dark green, mauve, medium blue, flame red and deep lavender.

The four colour temperature correction grades (Full and Half Colour Temperature Blue, and Full and Half Colour Temperature Orange) are used to balance colour temperature when working in a combination of daylight and tungsten lighting conditions.

Two Neutral Density (0.3 ND and 0.6 ND) grades can be used to reduce the power of a flash head or studio lamp, to balance the intensities of lights or flash. Completing the package are two white diffusers, for use on their own or with other filters to eliminate shadows and soften the overall lighting effect.



Reflector pack

Containing reflectors in mirror gold, mirror silver, soft gold and soft silver, the sheets are all manufactured from the same high quality, lightweight and flexible material that you would expect from LEE Filters. They can be used as they are, or mounted on polystyrene or board for added rigidity. They are ideal for use in both the studio or out on location.

Pro-Pack and Reflector packs are supplied in 610mm x 530mm sheets.

Polariser (lighting)

This is available in a 430mm by 300mm sheet and is intended for use with light sources. Care must be taken not to position the filter too close to a hot lamp.

Colourmagic

The LEE Filters **colourMAGIC** series is a set of eight individual packs each containing a selection of 12 filters (250mm x 300mm), related to a particular aspect of lighting and studio work. **colourMAGIC** offers an opportunity to get to know the performance of the various filters on offer in a cost-effective way.

Original pack

a specific selection of colours that can be used together to create a range of additional colours.



Contents - yellow, medium blue green, light blue, fern green, mauve, bright pink, heavy frost, no colour blue, chrome orange, dark lavender, flesh pink, brushed silk.

Light tint pack

paler shades to give more subtle effects and to filter white light from the lamp.



Contents - lavender tint, pale yellow, pale amber gold, light pink, mist blue, pale blue, straw, pale rose, bastard amber, lilac tint, white flame green, hollywood frost.

Studio pack

a range of technical filters for basic light source control.



Contents - 2x full CTB, 2x three quarters CTB, 2x full CTO, 2x three quarters CTO, 0.15 neutral density, 0.3 neutral density, 0.6 neutral density, 0.9 neutral density.

Tint pack

lighting filters which complement the original colour magic pack to create alternative shades.



Contents - rose pink, rose purple, lime green, spring yellow, english rose, marine blue, pink, flame red, dark steel blue, brushed silk, half white diffusion, violet.

Studio plus pack

a range of technical filters for fine control of light sources.



Contents - 2x half CTB, 2x quarter CTB, 2x eighth CTB, 2x half CTO, 2x quarter CTO, 2x eighth CTO.

Complementary pack

a starter pack for exploring the basics of colour addition and subtraction.



Contents - flame red, dark green, dark blue, loving amber, dark steel blue, pale green, yellow, peacock blue, bright pink, pale yellow, steel blue, light pink.

Saturates pack

a selection of strong and vibrant colours for more intense colour combinations.



Contents - medium red, yellow, orange, medium blue green, deep blue, mauve, heavy frost, deep golden amber, primary green, congo blue, light red, special rose pink.

Arc correction pack

a selection of technical filters for colour correction.



Contents - 2x half CTO, 2x quarter CTO, Lee fluorescent green, Lee fluorescent 5700K, Lee fluorescent 4300K, Lee fluorescent 3600K, 2x full plus green, 2x half plus green.

The CTB and the CTO and their derivatives are designed to change the colour temperature of the light source on which they are placed. See LEE Filters lighting brochure for further information.

Index

80A	44, 46	Colour temperature adjustment filters	46	Infrared (IR)	49
80B	46	Colour temperature set	44	Inspiring professionals	8
80C	44, 46	Combination filters	21, 47	Landscape Polariser	31
80D	46	Coral 1, 3, 5, 7, 8, 9, 10, 11, 12, 13, 14	40	Landscape set	35
81	44, 46	Coral 2	36, 40	Lens hoods	16
81A	44, 46	Coral 4	36, 40	Lighting filters	55
81B	44, 46	Coral 6	36, 40	Little Stopper	24
81C	46	Coral set	36	Low contrast 1/4, 1/2, 3/4, 1, 11/2	42
81D	44, 46	Coral stripe	34, 40	Magenta	37, 41
81EF	46	Cyan	37, 41	Magenta set	45
81EFN3, 81EFN6, 81EFN9	47	Daylight fluorescent set	44	Mahogany 1	35, 41
82	46	Digital starter kit	4	Mahogany 2	41
82A	44, 46	Field Pouch	52	Mahogany 3	37, 41
82B	46	Fine colour temperature set	44	Mist graduated	38, 42
82C	44, 46	FL 3600-B	45, 48	Mist clear spot	38, 42
85	46	FL 3600-D	44, 48	Mist set	38
85BN3, 85BN6, 85BN9	47	FL 4300-B	45, 48	Mist stripe	38, 42
85N3, 85N6, 85N9	47	FL 4300-D	44, 48	Multi-filter pouch	53
Accessories	54	FL 5700-B	45, 48	MV-B	48
Adaptor rings	14	FL 5700-D	44, 48	MV-D	48
Arc correction filters (CC/CT)	48	Fluorescent correction filters (CC/CT)	48	Net black 1	38, 42
Autumn tint set	34	Fog 1, 2, 3, 4, 5	42	Net black 2	38, 42
Big Stopper	24	Foundation kit	7, 12	Net set	38
Black & white set	45	Glass filters	19	Net white	38, 42
Black & white filters (CC/CT)	50	Green 1	37, 40	Neutral density 0.3 (resin)	22, 42
Blue pop	38, 40	Green pop	38, 40	Neutral density 0.45 (resin)	22, 42
Canon 17mm TS-E Adaptor Ring	15	Hard graduated filters	20	Neutral density 0.6 (resin)	22, 42
Chocolate 1	40	HPS-B	48	Neutral density 0.75 (resin)	22, 42
Chocolate 2	34, 40	HPS-D	48	Neutral density 0.9 (resin)	22, 42
Colour control filters	46	Holders	12		
Colour grad set	37				
ColourMAGIC series	56				

Index

Neutral density filters (polyester)	47	Real blue 1	41	Sunset 1, 3	39
Neutral density graduated	22, 33	Real blue 2	35, 41	Sunset 2	34, 39
Neutral density set (polyester)	45	Real blue 3	41	Sunset orange	37, 39
Neutral density set (resin)	33	Red pop	38, 39	Sunset red	37, 39
Neutral density single filters (polyester)	47	Reflector pack	55	Sunset set	37
Neutral density single filters (resin)	42	Resin filters	19, 32	Sunset yellow	37, 39
Neutral density standard	23	Selective star set	38	System accessories	54
Pale coral stripe	37, 39	Sepia 1, 3	40	Technical filters	43
Pale tint set	37	Sepia 2	35, 40	Technical filter sets	44
Pink 1	37, 41	Single effect resin filters	39, 40, 41, 42	Tobacco 1, 3	40
Pink stripe	41	Sky blue 1, 2	36, 41	Tobacco 2	34, 40
Polariser (lighting)	55	Sky blue 3	34, 36, 41	Tricolour filters (TR)	49
Polarising filters	28	Sky blue 4, 5	41	Tungsten fluorescent set	45
Polyester filters	19, 43	Sky blue set	36	Twilight	37, 41
Pop blue	38, 40	Sky set	34	Twilight set	37
Pop green	38, 40	Soft graduated filters	20	Ultraviolet absorbing filters (CC/CT)	48
Pop red	38, 39	Soft set	46	Universal lens hood	7, 17
Pop set	38	Starter kit	13	Upgrade kit	13
Pouches	52	Star eight point	38, 42	Warm-up set	44
Professional kit	13	Star four point	38, 42	Wideangle lens hood	17
ProGlass filters	23	Star six point	38, 42	Xposure Magazine	8
Pro-pack	55	Stopper Case	53	Yellow	37, 39
Push-on filter holder	13	Straw 1	39		
		Straw 2	35, 39		
		Straw 3	35, 39		
		Straw stripe	35, 39		
		Sunrise set	35		

Contact details

LEE Filters, Central Way,
Walworth Business Park, Andover,
Hampshire, SP10 5AN UK
T: + 44 (0) 1264 366245
F: + 44 (0) 1264 355058
sales@leefilters.com
leefilters.com

LEE Filters USA,
2237 North Hollywood Way,
Burbank, CA 91505 USA
T: (800) 576 5055
F: (818) 238 1228
sales@leefiltersusa.com
leefilters.com



INSPIRING PROFESSIONALS

leefilters.com